



FRESHPOINT® GRO-575B

FIVE STAGE REVERSE OSMOSIS SYSTEM



APPLICATIONS

- ◆ Drinking water

FEATURES • BENEFITS

- ◆ Reduces more than 90% of contaminants found in water
- ◆ Effortless click-in cartridge change-outs
- ◆ Color-coded cartridges help maintain proper filter sequence
- ◆ 3/8" push fittings for easy installation
- ◆ High efficiency membrane technology delivers up to 75 gallons per day
- ◆ Certified to reduce up to 98% of PFOA/ PFOS, commonly known as "forever chemicals"

INSTALLATION TIPS

- ◆ Choose a mounting location suitable to support the full weight of the system when operating.
- ◆ Install vertically with the cartridge hanging down.
- ◆ System may be installed with cartridge flush to the baseboard if desired as the mechanical assist lever pushes cartridges straight out.

OPERATION TIPS

- ◆ Replace pre/post filters every year and RO membrane every 18 months.
- ◆ Place replacement cartridges in proper sequence utilizing color-coded shapes.
- ◆ System is designed with integrated check valves so cold water line does not need to be shut off to perform cartridge change-outs.

INCLUDES

- ◆ Air gap side faucet
- ◆ Installation kit
- ◆ Installation and operation manual
- ◆ 4.4 gallon storage tank

FRESHPOINT GRO-575B FIVE STAGE REVERSE OSMOSIS SYSTEM

SPECIFICATIONS

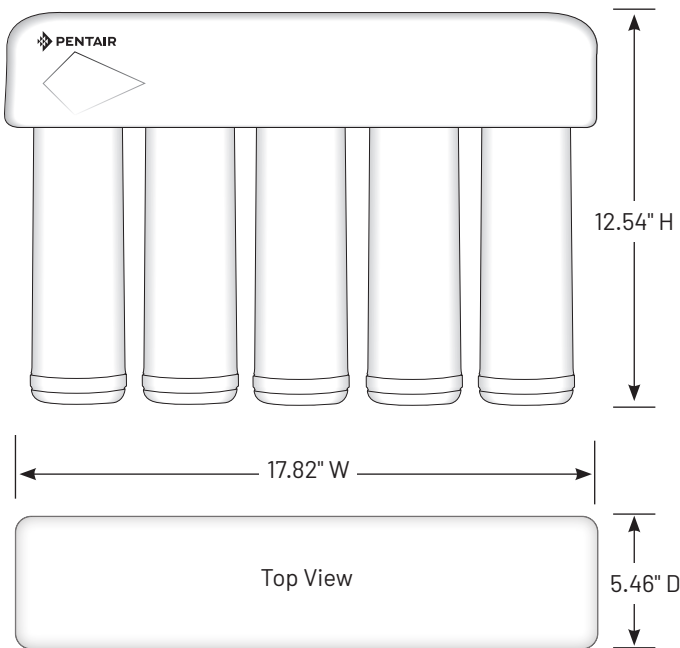

- ◆ **System (Model/Part No.)**
GRO-575B/161112
- ◆ **Inlet Size**
3/8" QC
- ◆ **System Dimensions**
17.82" W x 5.46" D x 12.54" H
(453 mm x 139 mm x 319 mm)
- ◆ **System Weight**
10.70 lbs (4.85 kg)
- ◆ **Contaminant Reduction**
Chlorine Taste & Odor
Nominal Particulate Class I
Atrazine
Lead
Lindane
Chloroform
Arsenic (Pentavalent) <= 50 ppb
Barium
Cadmium
Chromium (Hexavalent)
Chromium (Trivalent)
Copper
Fluoride
Radium 226/228
Selenium
Turbidity
TDS
VOCs
PFOA/PFOS
Cyst: NSF/ANSI Standards 53 and 58 certified to reduce cysts such as *Cryptosporidium* and *Giardia* by mechanical means.
- ◆ **TDS Rejection**
96.30%
- ◆ **Approximate Filter Life***
Pre/Post Filters: 1 year
RO Membrane: 18 months
- ◆ **System Production Rate**
21.08 gpd (79.77 Lpd)
- ◆ **Recovery Rating**
41.05%
- ◆ **Certifications**
NSF/ANSI Standards 42/53/58
CSA Standard B483.1
- ◆ **Feed Pressure Range**
40 - 100 psi (2.75 - 6.89 bar)
- ◆ **Temperature Range**
40 - 100°F (4.4 - 37.8°C)
- ◆ **Replacement Cartridges**
(Model/Part No.)
F1GC-RC/655117-96
FDF1-RC/655123-96
F2B2-RC2/655126-96 (twin pack)
GRO75-RC/655122-96

* Filter life dependent on gallon usage and overall incoming water quality.

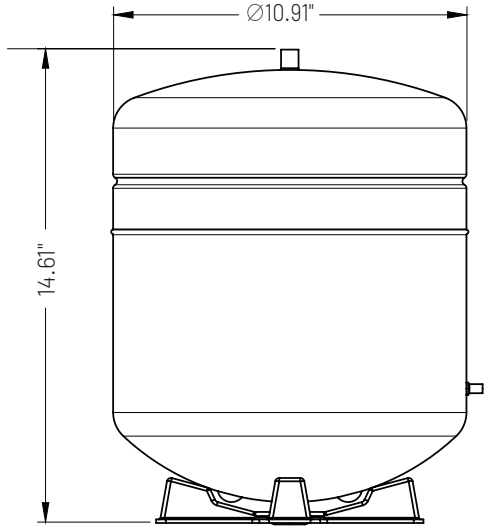

EPA EST. NO. 082989-CHN-001



The Models GRO-575B and GRO-575M are Tested and Certified by NSF International against NSF/ANSI Standards 42, 53, 58 and CSA B483.1 for the reduction of substances specified in the service manual or at www.nsf.org.



The Models GRO-575B and GRO-575M are certified by IAPMO R&T against NSF/ANSI 53 for the reduction of perfluorooctanoic acid (PFOA) and perfluorooctane sulfonate (PFOS).



13845 Bishops Dr. | Suite 200 | Brookfield, WI 53005 | United States
 P: 262.238.4400 | Customer Service: 800.279.9404 | tech-support@pentair.com | pentair.com

All indicated Pentair trademarks and logos are property of Pentair. Third party registered and unregistered trademarks and logos are the property of their respective owners.

© 2022 Pentair. All rights reserved.

4006660 DE22